

UPC Paris Local Division, 5 February 2025, Hurom v NUC

juice extraction module for juicer

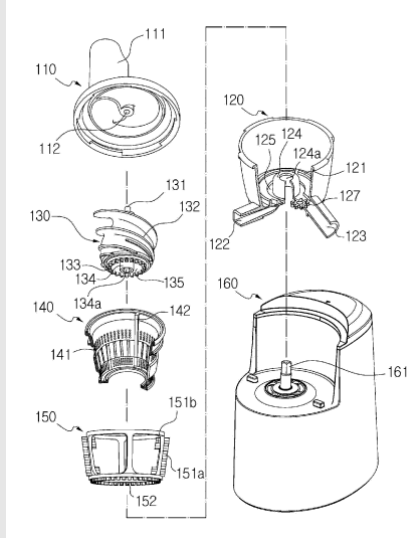

PATENT LAW – PROCEDURAL LAW

New arguments on infringement in Rejoinder by Hurom are inadmissible as not addressing matters raised in the Reply ([R. 32\(3\) RoP](#))

- [In particular, R 32-3 RoP in fine expressly states that “The Rejoinder shall be limited to the matters raised in the Reply.”](#)

In the case at hand, NUC and WARMCOOK had the last word in workflow 1 dedicated to the infringement and its remedies, in their statement lodged on 16/11/2024.

In HUROM's statement filed on December 16, 2025, which is part of workflow 3 of the written procedure, the Claimant was required to respond solely to the validity of the patent including the proposed amendment issues, presented in their statement from NUC and WARMCOOK dated November 14, 2024. If HUROM considered that new arguments regarding the infringement issue needed further submissions, it was up to HUROM to submit a reasoned request to the judge-rapporteur pursuant to [R 36 RoP](#).

Thus, the judge-rapporteur notes that the Defendants rightly considered in their ultimate Rejoinder dated January 15, 2025, that the new arguments on infringement put forward by HUROM in its Rejoinder dated December 16, 2024, were inadmissible at this stage, concerning these sections:

Hurom’s request for further exchange of written pleadings allowed because of new arguments raised by defendants ([R. 36 RoP](#))

- [without affecting the timeframe of the proceedings \(Interim Conference is scheduled for 11 March 2025\).](#)

The Defendants did not contest that they raised new arguments on infringement issues in their statement

dated November 16, 2024. According to HUROM, their last response should be concise (no more than 8 pages). To secure fairness and equity of the proceedings, and regarding the short timeline requested by the Applicant, the judge-rapporteur considers that HUROM’s request can be granted without affecting the timeframe of the proceedings (Interim Conference is scheduled for 11 March 2025).

Further exchange of written pleadings allowed under [R. 36 RoP](#)

In accordance with the main principle of fairness ([point 2 of the preamble](#)), [R 36 RoP](#) allows the parties to request further written submissions to the judge-rapporteur upon reasoned request. Under [R 36 RoP](#), the parties have the right to ask for further statements before the closure of the written procedure.

The Defendants did not contest that they raised new arguments on infringement issues in their statement dated November 16, 2024. According to HUROM, their last response should be concise (no more than 8 pages). To secure fairness and equity of the proceedings, and regarding the short timeline requested by the Applicant, the judge-rapporteur considers that HUROM’s request can be granted without affecting the timeframe of the proceedings (Interim Conference is scheduled for 11 March 2025).

Source: [Unified Patent Court](#)

UPC Paris Local Division, 5 February 2025

(Lignières)

UPC_CFI_163/2024

PROCEDURAL ORDER

of the Court of First Instance of the Unified Patent Court delivered on 05/02/2025

concerning further exchanges of written pleadings ([R. 36 RoP](#))

APPLICANT - CLAIMANT

1) Hurom Co., Ltd

80-60 Golden root-ro, Juchon-myeon
62184 - Gimhae-si, Gyeongsangnam-do - KR

Represented by Sabine Agé

RESPONDENTS - DEFENDANTS

1) NUC Electronics Co., Ltd

280, Nowon-ro

41548 - Buk-gu, Daegu - KR

Represented by Didier INTES

2) NUC Electronics Europe GmbH

Schwalbacher Straße 76

65760 - Eschborn - DE

Represented by Didier INTES

3) Warmcook

73 boulevard Gay Lussac

13014 - Marseille - FR

Represented by Didier INTES

PATENT AT ISSUE

Patent no. [EP3155936](#)

Proprietor HUROM Co., Ltd

DECIDING JUDGE

Presiding judge & Judge-rapporteur Camille Lignières

LANGUAGE OF PROCEEDINGS:

English

ORDERFacts and history of the proceedings

HUROM (the “Claimant” or the “Applicant” in this application) filed an infringement action based on patent EP’ 936 against the NUC entities and WARMCOOK (the “Defendants” in the main action and this application).

The parties have already exchanged their statements, as follows:

- Statement of Claim from HUROM on April 3, 2024,
- Statement of Defence and counterclaims for revocation of the Patent from NUC and WARMCOOK, on July 17, 2024,
- Reply from HUROM, including an application to unconditionally amend the Patent, on September 17, 2024,
- Rejoinder from NUC and WARMCOOK on November 14, 2024,
- the Claimant Rejoinder from HUROM on December 16, 2024,
- the Ultimate Rejoinder from NUC and WARMCOOK on January 15, 2025.

On January 21, 2025, the judge rapporteur informed by email the parties that, according to [Rule 35](#) of the Rules of Procedure, she planned to close the written procedure in this case on January 27, 2025.

On January 24, 2025, HUROM submitted a request under [R.36 RoP](#) for further statements, asking the Court to:

- declare that the sections of the Claimant's Rejoinder challenged by the Defendants are admissible,
- alternatively, permit both Parties to submit further statements to address the new points raised by the Defendants in their Rejoinder.

On January 27, 2025, the judge rapporteur issued a preliminary order requesting the defendants to provide their written comments on HUROM's request.

On the same day, NUC and WARMCOOK filed their comments requesting the rejection of the HUROM application, arguing the following:

- the admissibility of the allegedly new arguments filed by the Defendants in the Rejoinder (dated November 14, 2024) has not been challenged by the Claimant in the Claimant Rejoinder, while the Claimant raised other inadmissibility issues,
- the allegedly new arguments filed by the Defendants in the Rejoinder actually consist in mere clarifications or answers to the Reply filed by Hurom, in the context of the unconditional amendment of the Patent by the Claimant,
- as defendants in infringement proceedings, the Defendants shall have the last word and be the latest party to present its arguments regarding the materiality of the infringement and the remedies.

Legal framework**“[Rule 12](#) – Exchange of written pleadings (infringement action)**

1. The written procedure shall consist of:

(a) the lodging of a Statement of claim (by the claimant) [[Rule 13](#)];

(b) the lodging of a Statement of defence (by the defendant) [[Rules 23](#) and [24](#)]; and, optionally

(c) the lodging of a Reply to the Statement of defence (by the claimant) [[Rule 29\(b\)](#)]; and

(d) the lodging of a Rejoinder to the Reply (by the defendant) [[Rule 29\(c\)](#)].

2. The Statement of defence may include a Counterclaim for revocation [[Rule 25.1](#)].

3. If a Counterclaim for revocation is lodged:

(a) the claimant and any proprietor who becomes a party pursuant to [Rule 25.2](#) (hereinafter in this [Rule 12](#) and [Rules 29](#) to [32](#), “the proprietor”) shall lodge a Defence to the Counterclaim for revocation [[Rule 29\(a\)](#)], which may include an Application to amend the patent by the proprietor [[Rule 30](#)];

(b) the defendant may lodge a Reply to the Defence to the Counterclaim [[Rule 29\(d\)](#)]; and

(c) the claimant and the proprietor may lodge a Rejoinder to the Reply to the Defence to the Counterclaim [[Rule 29\(e\)](#)].

4. If an Application to amend the patent is lodged by the proprietor, the defendant shall lodge a Defence to the Application to amend the patent in the Reply to the Defence to the Counterclaim, the proprietor may lodge a Reply to the Defence to the Application to amend and the defendant may lodge a Rejoinder to such Reply [[Rule 32](#)].

5. The judge-rapporteur may allow the exchange of further written pleadings, within time periods to be specified [[Rule 36](#)].”

[Rule 32.3 RoP](#):

“The proprietor may lodge a Reply to the Defence to the Application to amend the patent within one month of service of the Defence and the defendant may within one month of the service of the Reply lodge a Rejoinder to the Reply. The Rejoinder shall be limited to the matters raised in the Reply.”

Grounds

As foreseen by [Rule 12 RdP](#), the rules of procedure divide the written procedure into several successive stages:

- workflow 1, relating to the infringement claim itself comprising a set of 4 statements,
- followed by workflow 2 dedicated to the validity of the patent in the event of a counterclaim for revocation of the patent at issue,
- finally, workflow 3 is specifically dedicated to the amendment of the patent at issue, if requested.

In workflow 1, the defendant in the infringement claim has the last word, in this case, NUC and WARMCOOK. In workflow 2, the defendant in the attack on the validity of the patent in question has the last word, in this case, HUROM.

Finally, in workflow 3, in the event of a request to amend the patent in question, the defendant to this request has the last word, in this case, NUC and WARMCOOK.

These workflows, with strict deadlines, are aimed to ensure the most efficient and economical procedure

before the UPC, in accordance with point 4 of the Preamble.

In particular, **R 32-3 RoP** in fine expressly states that “The Rejoinder shall be limited to the matters raised in the Reply.”

In the case at hand, NUC and WARMCOOK had the last word in workflow 1 dedicated to the infringement and its remedies, in their statement lodged on 16/11/2024.

In HUROM's statement filed on December 16, 2025, which is part of workflow 3 of the written procedure, the Claimant was required to respond solely to the validity of the patent including the proposed amendment issues, presented in their statement from NUC and WARMCOOK dated November 14, 2024. If HUROM considered that new arguments regarding the infringement issue needed further submissions, it was up to HUROM to submit a reasoned request to the judge-rapporteur pursuant to **R 36 RoP**.

Thus, the judge-rapporteur notes that the Defendants rightly considered in their ultimate Rejoinder dated January 15, 2025, that the new arguments on infringement put forward by HUROM in its Rejoinder dated December 16, 2024, were inadmissible at this stage, concerning these sections:

- Section 2 “On the infringement” (p. 48 to 51) of the Claimant Rejoinder; and
- Section 3 “On the remedies” (p. 52 to 56) of the Claimant Rejoinder; and
- the supporting pieces of evidence referred to in this Section (Hurom Exhibits No. 27.1 and 27.2).

In accordance with the main principle of fairness (**point 2 of the preamble**), **R 36 RoP** allows the parties to request further written submissions to the judge-rapporteur upon reasoned request. Under **R 36 RoP**, the parties have the right to ask for further statements before the closure of the written procedure.

The Defendants did not contest that they raised new arguments on infringement issues in their statement dated November 16, 2024. According to HUROM, their last response should be concise (no more than 8 pages). To secure fairness and equity of the proceedings, and regarding the short timeline requested by the Applicant, the judge-rapporteur considers that HUROM's request can be granted without affecting the timeframe of the proceedings (Interim Conference is scheduled for 11 March 2025).

Considering all these elements, the judge-rapporteur:

-Declares that arguments mentioned in sections 2 and 3 in HUROM's statement of 15/01/2025 are inadmissible,

-Authorises further exchanges of written pleadings, as follows:

-Last statement from HUROM, strictly dedicated to responding to the new arguments presented by the Defendants in their Rejoinder dated November 14, 2024, regarding infringement and its remedies, (maximum of 8 pages), due by 10 February 2025,

-Response from NUC and WARMCOOK, strictly dedicated to addressing the points raised by HUROM in its latest statement (maximum of 8 pages), due by 15 February 2025.

The written procedure will be closed at the end of this last exchange.

This order may be reviewed pursuant to **Rule 333 RoP**. Issued in Paris, on 5 February 2025.

C. Lignieres, Judge-rapporteur

ORDER DETAILS

Order no. ORD_4336/2025 in ACTION NUMBER: ACT_17434/2024

UPC number: UPC_CFI_163/2024

Action type: Infringement Action Related proceeding no. Application No.: 4027/2025

Application Type: **R 36** application
