

## UPC Court of Appeal, 14 January 2025, Total Semiconductors v Texas Instruments

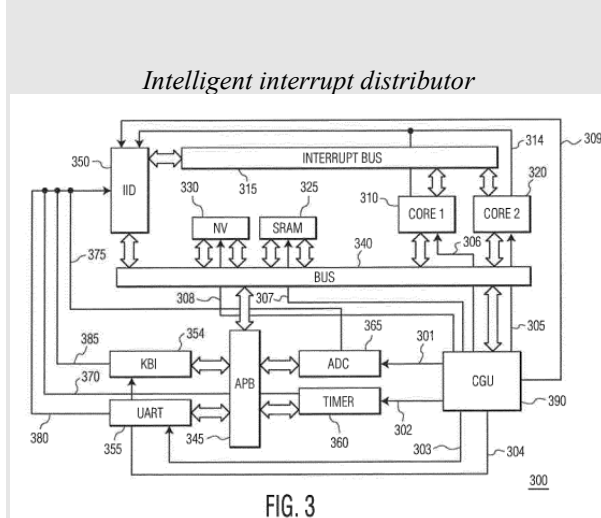

### PATENT LAW – PROCEDURAL LAW

Justified to allow discretionary review in appeal of orders of the judge-rapporteur (absent panel review) (R. 220.3 RoP)

- The question whether the judge-rapporteur could decide alone on security for costs of a party and deny leave to appeal is an access to justice issue which the Court of Appeal can raise of its own motion

Possible for judge-rapporteur or the presiding judge to order security for costs

- R. 158 RoP does not exclusively reserve orders on security for costs for a panel of the Court.

This flexibility allows the judges to organise the proceedings in the most efficient and cost effective manner (preamble of the RoP, at para 4).

Order on security for costs (R. 158 RoP) must be considered a case management order,

- making it subject to review by the panel (R. 333.1 RoP). System implies a broad interpretation of “case management decision or order”

Judge-rapporteur not competent to decide on leave to appeal in his order on security for cost (R. 158 RoP, R. 220.2 RoP, R. 333.1 RoP)

- Would circumvent the system with panel review. It is therefore only the panel, after panel review, that can decide on leave to appeal.

Source: Unified Patent Court

UPC Court of Appeal,  
14 January 2025

(Kalden, Simonsson, Rombach)

UPC\_CoA\_651/2024

APL\_59329/2024

ORDER

of the Court of Appeal of the Unified Patent Court issued on 14 January 2025 on composition of the Court in orders for security for cost of a party (R. 158 RoP)

#### HEADNOTES:

- An order on security for costs pursuant to R. 158 RoP is a case management order. Such orders can be reviewed by the panel on its own motion or at the request of a party (R. 333 RoP).

- If the judge-rapporteur or presiding judge issues an order on security for costs, the judge-rapporteur or presiding judge is not competent to decide on leave to appeal. Leave to appeal should be assessed by the panel after panel review.

#### KEYWORDS:

- Composition of the Court, panel review

**APPELLANT (AND CLAIMANT BEFORE THE COURT OF FIRST INSTANCE)**

**TOTAL SEMICONDUCTOR, LLC**, Plano, Texas, USA (hereinafter ‘Total’)

represented by: Dr. Thomas Lynker, Rechtsanwalt, TALIENS, Munich, Germany

**RESPONDENTS (AND DEFENDANTS BEFORE THE COURT OF FIRST INSTANCE)**

1. **Texas Instruments EMEA Sales GmbH**, Freising, Germany

2. **Texas Instruments Deutschland GmbH**, Freising, Germany

(hereinafter jointly referred to as ‘TI’)

both represented by: Klaus Haft, Rechtsanwalt, HOYNG ROKH MONEGIER, Düsseldorf, Germany

**PATENT AT ISSUE**

EP 2 746 957

**LANGUAGE OF THE PROCEEDINGS**

English

**PANEL AND DECIDING JUDGES**

**IMPUGNED ORDER OF THE COURT OF FIRST INSTANCE**

□ Date: 16 October 2024, ORD\_38103/2024, App\_29561/2024, UPC\_CFI\_132/2024, Mannheim Local Division

**POINT AT ISSUE**

Security for costs of a party (R. 158 RoP)

**ORAL HEARING ON**

16 December 2024 (by videoconference with the consent of the parties)

**SUMMARY OF FACTS AND INDICATION OF PARTIES’ REQUESTS**

1. Through the impugned order, the Mannheim Local Division ordered, with reference to Art. 69 (4) UPCA and R. 158 RoP, Total to provide security in an amount of € 600.000 either by deposit or by a bank guarantee issued by a bank licensed in the European Union, within eight weeks from the date of service of the order. The Local Division reminded that in case of failure to provide security within the stated period of time, a decision by default may be given, in accordance with R. 355 RoP. Leave to appeal was refused. The order was adopted by the judge-rapporteur. On information about appeal it was stated that R. 158.3, 220.2 RoP do not apply because the leave to appeal was refused.

2. Total made a request to the Court of Appeal for discretionary review. On 27 November 2024, the standing judge issued an order pursuant to [R. 220.4 RoP](#). There, the standing judge made the preliminary assessment that it may be questioned, as to whether a judge-rapporteur is competent to issue an order on security for the legal costs and other expenses incurred and/or to be incurred by the requesting party pursuant to [R. 158 RoP](#) and deny leave to appeal or if such an order should be adopted by the panel, or, if adopted by the judge-rapporteur, be subject to review by the panel. Following comments from the parties on this, the standing judge allowed the request for discretionary review on the question whether the judge-rapporteur could decide alone on security for costs of a party and deny leave to appeal. The leave to appeal did not extend to the substantive matter of security for costs in the impugned order.

3. At the oral hearing, Total explained, in view of the limited scope of the leave to appeal, that it requests that the impugned order be set aside and the case referred back to the Court of First Instance. Auxiliary, it requests that the denial on leave to appeal be set aside and that the order be referred to the Court of First Instance panel for review pursuant to [R. 333.1 RoP](#).

4. TI requests that the appeal be dismissed and that Total be ordered to bear the costs.

#### PARTY'S SUBMISSIONS

5. Total has (in summary) submitted the following.

- The judge-rapporteur might not have had the legal competence to issue an order on security for costs. At least, there is no explicit provision in the Rules of Procedure granting such competence to the judge-rapporteur. [R. 1.2 RoP](#) does not grant the judge-rapporteur general competence but only clarifies in general terms that different acts may also be performed by different judges. [R. 345.4 RoP](#) does not seem to be applicable in relation to an order for security for costs either.
- By expressly refusing leave to appeal while nevertheless providing under “Information about Appeal” that [R. 158.3](#), [220.2 RoP](#) do not apply because the leave to appeal is refused, the judge-rapporteur created the clear and unambiguous impression of a final and binding order of the Court regarding the security for costs and that such an order could generally be subject to an appeal, but that in the case at hand leave to appeal was refused.
- An order for security for cost is not a case management order.
- The only available remedy in the case at hand was the request for discretionary review.
- There is nothing in the Rules of Procedure or the case law of the Court of Appeal suggesting that a panel review has to be sought first in a situation like the one at hand. There is also no CMS workflow available.
- The request for discretionary review cannot be dismissed just because the order for security of costs was not issued by the panel or with the reasoning that Total should have used a different (implausible) remedy. Whether one can appeal is integral in an order

and it would be artificial to look at an order and the right to appeal the same order as two separate legal concepts.

6. TI has (in summary) submitted as follows.

- The request for discretionary review is not admissible because only panel decisions – not orders of the judge-rapporteur – can be subject to discretionary review.
- An order regarding the security for costs of a party under [R. 158 RoP](#) is a case management order and the judge-rapporteur is competent to issue such an order. The affected party is entitled to request a panel review of the judge-rapporteur order within 15 days after it was served and the judge-rapporteur can refer any decision to the panel. The panel can even *ex officio* review every decision of the judge-rapporteur.
- Total did not request a panel decision, neither before nor after the order was issued.
- By refusing “leave to appeal”, the judge-rapporteur order merely states the obvious. An order issued by the judge-rapporteur as such cannot be subject to an appeal under [R. 220.2 RoP](#) because the scope of [R. 220.2 RoP](#) is limited to panel decisions.
- The impugned order wrongfully states that [R. 220.2 RoP](#) is not applicable, but this does not change what has been said about the mandate of the judge-rapporteur, nor the obligation of Total to seek panel review.
- The question raised by the Court of Appeal should not be the subject of the discretionary review because it was not raised by Total.
- It can not be expected that a panel review of the judge-rapporteur order would have led to a different outcome.
- Total has set out no valid reasons why an appeal against the order should be heard.

#### GROUND FOR THE ORDER

##### *Admissibility*

7. It is possible to make a request for discretionary review to the Court of Appeal under [R. 220.3 RoP](#) in the event leave to appeal of an order of a panel is refused (see [CoA, order on 21 March 2024, UPC CoA 486/2023, App 595643/2023, Netgear vs Huawei](#)). However, the facts of the case raise the question as to whether the judge-rapporteur could decide alone on security for costs of a party and decide whether or not to grant leave to appeal. The fact that the judge-rapporteur himself decided on this, rather than have the panel decide, prevents that a request for discretionary review pursuant to [R. 220.3 RoP](#) may be made, since there is no panel order. This would however only be justified if the underlying reasoning of the judge-rapporteur to consider himself competent to decide on these two matters, is indeed accurate.

8. Under these circumstances, it was justified for the standing judge to allow the request for discretionary review on the question whether the judge-rapporteur could decide alone on security for costs of a party and deny leave to appeal. This is an access to justice issue which the Court of Appeal can raise of its own motion.

*Whether a judge-rapporteur can issue an order on security for costs*

9. According to [R. 158 RoP](#) it is for the Court to order that a party shall provide adequate security for the legal costs and other expenses incurred and/or to be incurred by the requesting party.

10. There is no wording in [R. 158 RoP](#) that such orders shall be adopted by the panel.

11. [R. 1.2\(a\) RoP](#) states that where the Rules provide for the Court to perform any act other than an act exclusively reserved (insofar as relevant here) for a panel of the Court, that act may be performed by the presiding judge or the judge-rapporteur of the panel to which the action has been assigned.

12. [R. 158 RoP](#) does not exclusively reserve orders on security for costs for a panel of the Court. It is by consequence possible for the judge-rapporteur or the presiding judge to issue such orders. This flexibility allows the judges to organise the proceedings in the most efficient and cost effective manner ([preamble of the RoP](#), at para 4).

***Whether such an order is subject to panel review***

13. From the system as laid down in the Rules of Procedure, in particular [R. 331 RoP](#) in conjunction with [R. 102](#) and [R. 333 RoP](#), on the basis of which decisions and orders by the judge-rapporteur under the mandate of the panel can always be reviewed, either at the initiative of the panel itself, or at the (reasoned) request of a party, it follows that there is a broad scope for review of actions of the judge-rapporteur. This system avoids unnecessary appeals to, and involvement of, the Court of Appeal in the event that the panel does not share the opinion of the judge-rapporteur (see [Netgear vs Huawei](#), para 28).

14. This system implies a broad, rather than a limited interpretation of 'case management decision or order' as meant in [R. 333.1 RoP](#) ([Netgear vs Huawei](#) at paras 33-35). It follows from this broad interpretation that an order on security for costs pursuant to [R. 158 RoP](#) must be considered a case management order. Consequently, such orders are subject to review by the panel, as provided for in [R. 333 RoP](#).

15. No other considerations follow from [R. 158.3 RoP](#). This Rule provides that the order for security shall indicate that an appeal may be lodged in accordance with [Article 73 UPCA](#) and [R. 220.2 RoP](#). Including such general terms in an order is a reference for information purposes to the provisions of the RoP applicable to proceedings before the Court of Appeal (CoA, 15 October 2024, CoA\_PC 01/2024, Photon Wave vs Seoul Viosys, at paras 7-8).

***Whether the judge-rapporteur can decide on leave to appeal***

16. As said, since an order pursuant to [R. 158 RoP](#) is a case management order and as such subject to panel review, the judge-rapporteur cannot decide on leave to appeal, because it would circumvent the system with panel review as set out above. It is therefore only the panel, after panel review, that can decide on leave to appeal.

17. The Court of Appeal concludes that the judge-rapporteur was not competent to decide on leave to appeal in his order on security for costs.

***The legal consequences of these findings***

18. Setting aside only the part of the order addressing leave to appeal would be of no use to Total since the time period for requesting panel review has expired ([R. 333.2 RoP](#)).

19. TI has argued that Total should have requested a panel review. Although there is normally such an obligation, the case at hand distinguishes itself because the information about appeal – that [R. 158.3, 220.2 RoP](#) did not apply because the leave to appeal was refused – conveyed the impression that the outcome was final. For this reason, Total cannot be blamed for turning to the Court of Appeal with a request for discretionary review. 20. To this can be added that there was a need for clarification on the question whether the judge-rapporteur could decide alone on security for costs of a party and decide on leave to appeal.

***Referral back to the Court of First Instance***

21. Since there was a need for clarification of the questions at hand, the outcome of this particular appeal represents an exceptional circumstance where it is justified to refer the issue back to the Court of First Instance ([R. 242.2\(b\) RoP](#)). The same panel whose judge rapporteur issued the revoked order shall deal with the action ([R. 243.1 RoP](#)). As explained above, an order on security for costs can be adopted by the judge-rapporteur, but only the panel, after panel review, can decide on leave to appeal.

***Costs***

22. The costs of the proceedings, including those of this appeal, shall be addressed by the Court of First Instance.

**ORDER**

1. The Court of Appeal revokes the order of the Local Division Mannheim, 16 October 2024, ORD\_38103/2024, App\_29561/2024, UPC\_CFI\_132/2024.

2. The same panel whose order is revoked shall deal further with the action ([R. 243 RoP](#)). The Court of First Instance can adjudicate on security for cost without consulting the parties and the principles on composition of the Court explained in this order apply.

Issued on 14 January 2025

Rian Kalden, Presiding judge and legally qualified judge  
Ingeborg Simonsson, legally qualified judge and judge-rapporteur

Patricia Rombach, legally qualified judge

-----