

UPC CFI, Central Division Paris, 27 February 2024,
Meril Italy v Edwards Lifesciences

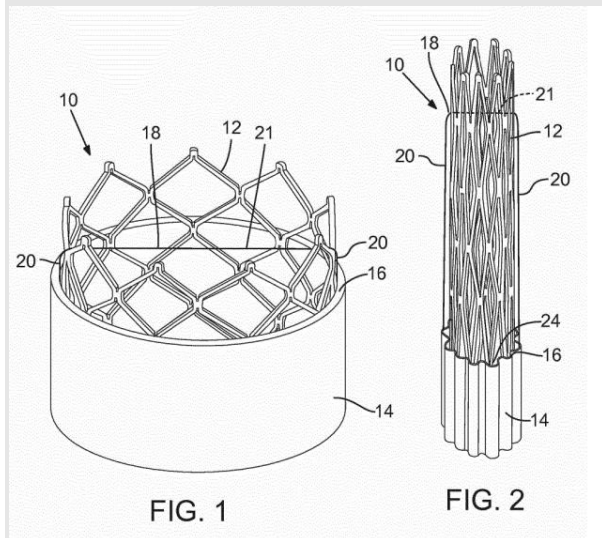

FIG. 1
FIG. 2
A system comprising a prosthetic valve
and a delivery catheter

PATENT LAW – PROCEDURAL LAW

Subsequent request to change original request to amend the patent rejected because of insufficient justification ([Rule 30\(2\) RoP](#))

Leave to change claim or amend case and application to amend patent can be filed simultaneously in one pleading, especially in a situation, where strict time periods come into play ([Rule 263 RoP](#), [Rule 30 RoP](#))

- [in accordance with the principles of flexibility, fairness and equity, mentioned in the preamble 2, 4 and 5 of the Rules of Procedures, as well as of the principle of procedural efficiency](#)

A request to replace the original application to amend the patent with a new set of amendments

- [is not governed by Rule 263 RoP but falls under Rule 50\(2\) RoP and pursuant to Rule 30\(2\) RoP such a subsequent request requires the permission of the Court \(Rule 263 RoP, Rule 30 RoP, Rule 50 RoP\)](#)

22. The expression ‘*amend its case*’ contained in [Rule 263 ‘RoP’](#), and to which the defendant has referred to, seems to be interpreted in connection of the previous expression ‘*change its claim*’, as they constitute a hendiadys which relates to any modification to the case by the means of the introduction of a new claim or the replacement of the original one (‘*change its claim*’), as the expressed reference to a counterclaim seems to evoke, or of the submission of new or different grounds of the claim (‘*amend its case*’).

23. It follows that the request to replace the original application to amend the patent with a new set of amendments appears to be outside the scope of said [Rule 263 ‘RoP’](#), as it does not pertain to a claim.

24. Actually, the particular case at hand, in which the patent proprietor applied to amend the patent in due time (that is, within the time period for lodging the defence to revocation) and then requested for a change of its original application with the rejoinder to the reply to the defence and the reply to the defence to the application to amend the patent, so that the new amendments superseded the previous ones, falls under [Rule 50 \(2\) ‘RoP’](#).

25. This Rule establishes that the application to amend the patent ‘*shall contain the matters referred to in [Rule 30.1 \(a\), \(c\)](#) and an explanation as to why the amendments satisfy the requirements of [Articles 84 and 123 \(2\), \(3\) EPC](#) and why the proposed amended claims are valid. [Rule 30.2](#) shall apply*’.

26. According to this latter [Rule 30 \(2\) ‘RoP’](#), any ‘subsequent request’ to amend the patent may only be admitted into the proceedings with the permission of the Court.

27. The term ‘subsequent’, present in [Rule 30 \(2\) ‘RoP’](#), referred to by [Rule 50 \(2\) ‘RoP’](#), has to be interpreted as regarding to an act which follows in succession a previous one and, therefore, it appears clear enough that the term relates to the original application to amend the patent and indicates any request to amend the patent – whether proposed in a completely new version or as an amend of a previous amend – which comes after the first one.

Justification of a request to change the original request to amend the patent required

- [in order to enable the Court to strike a fair balance between the opposed interests involved in the request to amend the patent \(Rule 30\(2\) RoP\)](#)

30. While using these discretionary powers the Unified Patent Court judges have to observe the principles of proportionality, flexibility, fairness and equity, mentioned in the [preamble 2 and 4 of the Rules of Procedures](#) (see, [UPC CFI 412/2023 CD Paris, order of 9 February 2024](#)).

31. With particular regard to the admission of a subsequent request to amend the patent, they have to take into account, on one hand, the fact that a subsequent amend of a patent may lead to a more efficient proceedings, narrowing the subject-matter and simplifying the procedural activities, and to a proper safeguard of the interest of the patent proprietor in controlling the scope of protection of its exclusive rights.

32. On the other hand, the admission of subsequent requests to amend the patent may affect the purpose of delivering an expeditious decision, forcing an extension of the time of the written procedure in relation to the right of the other parties to arrange the consequent defence, and may undermine the right of defence of these latter parties.

The development in Munich LD proceedings does not justify the subsequent request to amend the patent.

- [not suitable to fulfil the declared purposes of consistency and procedural economy.](#)

39. Moreover, the tool offered by [Rule 295 \(m\) 'RoP'](#) may come at hand, pushing one of the divisions to stay its proceedings until the decision of the other division and then to decide accordingly on the validity issue.

40. In general, the Unified Patent Court framework does not exclude that a patent may be attacked by different subjects, with different claims, on different grounds and before different divisions and in such a situation the purpose of consistency of the decisions is safeguarded by the mentioned tools and does not require that the patent proprietor has all its defences in the different proceedings in which its patent is attacked aligned.

Request to hear the revocation action together with the counterclaims in the Munich Local Division proceedings rejected ([Rule 340\(1\) RoP](#))

- [the application of that Rule does not appear to be actual, as no hearing seems to have been set in the two proceedings](#)

51. The opinion of this panel is that this request may have not been made at this stage of the proceedings: firstly, because the lodging of the defendant's pleading has been authorised by the judge-rapporteur with regard to the only purpose of commenting the claimant's application.

52. Secondly, regardless to any considerations about the scope of [Rule 340 'RoP'](#), the application of that Rule does not appear to be actual, as no hearing seems to have been set in the two proceedings

Leave to appeal rejected ([Article 73 UPCA](#), [Rule 220 RoP](#))

- [in the absence of any precedents from the UPC on the disputed issue, there is no concrete need for a ruling on the meaning of the relevant rules; In case of a possible immediate appeal to this order a decision by the Court of appeal may intervene after that the oral hearing in the current proceedings has taken place and, therefore, would be of no practical use to the parties](#)

53. The panel decides not to grant leave to appeal, because, in the absence of any precedents from the Unified Patent Court on the disputed issue, there is no concrete need for a ruling on the meaning of the relevant rules.

54. Furthermore, the panel reminds the parties that, as previously mentioned, a different set of amendments may be reached, upon their agreement, during the course of the proceedings.

55. Lastly, the panel notes that in case of a possible immediate appeal to this order a decision by the Court of appeal may intervene after that the oral hearing in the current proceedings has taken place and, therefore, would be of no practical use to the parties.

Source: [Unified Patent Court](#)

UPC Court of First Instance,
Central Division Paris, 27 February 2024

(Catalozzi, Zhilova, Wilhelm)

ORDER

ORDER

of the Court of First Instance of the Unified Patent Court
Central division (Paris seat)

issued on 27 February 2024

concerning the Generic Application No.
App_7184/2024

lodged in the revocation action UPC_CFI_255/2023

HEADNOTES: [Rule 30 'RoP'](#).

KEYWORDS: subsequent request to amend the patent;
request to amend the case.

REFERENCE CODE ECLI:

APPLICANT:

Meril Italy srl - Piazza Tre Torri 2 20145 Milano Italy
represented by Emmanuel Larere, Cabinet Gide Loyrette
Nouel AARPI assisted by Raphaëlle Dequiré-Portier,
Cabinet Gide Loyrette Nouel AARPI

RESPONDENT:

Edwards Lifesciences Corporation - 1 Edwards Way,
Irvine, 92614 California, USA,

represented by Boris Kreye, Bird & Bird LLP

co-represented by Siddharth Kusumakar and Tessa
Waldron, Powell Gilbert (Europe) LLP

PATENT AT ISSUE:

European patent n° [EP 3646 825](#)

PANEL:

Panel 2 of the Central Division - Paris Seat

DECIDING JUDGE:

This order is issued by the panel

SUMMARY OF FACTS AND PARTIES' REQUESTS:

1. On 4 August 2023 the applicant lodged a revocation action against patent at issue (EP '825) before this Seat of the Court of First Instance of the Unified Patent Court, registered as No. ACT_551308/2023 UPC_CFI_255/2023.

2. On 16 October 2023, the respondent, defendant in the revocation action, lodged the statement of defence which included a conditional application to amend the patent.

3. On 28 November 2023 the claimant submitted a Generic procedural application, registered as No. App_509828/2023, requesting to the judge-rapporteur to reject as inadmissible the application to amend the patent and, as an auxiliary request, to order to the defendant to comply with [Rule 30 \(1\)](#) of the Rules of Procedures ('RoP') and to modify its application to amend EP '825 accordingly.

4. This application has been rejected as this judge-rapporteur has deemed that it was not appropriate to address the admissibility of the request to amend the patent at this stage of the proceedings (see UPC CFI 255/2023 CD Paris, order of 21 December 2023).

5. Therefore, on 22 December 2023 the claimant submitted its reply to the defence together with a reply to the application to amend the patent.

6. Then, on 22 January 2024 the defendant lodged its rejoinder to the reply to the defence together with the reply to the defence to the application to amend the patent; moreover, with the same pleading it requested to the Court for a leave to amend its case, pursuant to [Rule](#)

263 (1) 'RoP' with regard to a new main request to amend the patent, as well as 41 auxiliary requests based on 9 individual amendments.

7. On 8 February 2024 the claimant submitted a Generic procedural application registered as No. App_7184/2024, requesting to refuse to admit the defendant's subsequent application to amend the patent and to refuse to grant leave to amend its original application to amend that patent and, as an auxiliary request, to grant it a fair deadline extension for filing its defence to the defendant's subsequent application to amend the patent.

8. In written comments lodged on 15 February 2024, the defendant requested that the claimant's requests be dismissed and, on an auxiliary basis, that the Court grant permission pursuant to **Rule 30(2) 'RoP'** to admit the defendant's request to amend of 22 January 2024.

9. Besides, it requested that should the Court not dismiss claimant's request of 8 February 2024 or grant permission to admit the request to amend the patent under **Rule 30 (2) 'RoP'**, the Court hears the parties pursuant to **Rule 264 (1) 'RoP'** and, furthermore, that the underlying revocation action be heard together with the counterclaims for revocation brought by Meril Life Sciences Pvt Ltd. and Meril GmbH before the Munich Local Division against the patent in suit (registered as No. ACT_459987/2023 UPC_CFI_15/2023) pursuant to Rule 340 (1) 'RoP' and should the Court not follow that request, the Court hears the parties pursuant to that Rule.

10. It also requested that, in the event that the Court rejects its requests, the Court grants leave to appeal the order.

11. The judge-rapporteur has deemed appropriate to refer the proposed order to the panel, pursuant to Rule **331 (2) 'RoP'**.

GROUND FOR THE ORDER

Application to amend the case without a previous leave.

12. By lodging its rejoinder to the reply to the statement of defence and reply to the defence to the application to amend the patent the defendant has applied to the Court for leave to amend its previous application to amend the patent at issue filed with the statement of defence, pursuant to **Rule 263 (1) 'RoP'**, and at the same time it has amended it.

13. The claimant has objected to it, complaining that the defendant should have first asked for the leave – or the permission if **Rule 30 'RoP'** would apply – and then, once granted, amend its application.

14. This panel does not agree with this argument.

15. While the way of action proposed by the claimant may appear more appropriate and respectful of the literal wording of **Rule 263 'RoP'** – as well as of **Rule 30 'RoP'** –, nevertheless these provisions have to be interpreted, in accordance with the principles of flexibility, fairness and equity, mentioned in the **preamble 2, 4 and 5** of the Rules of Procedures, as well as of the principle of procedural efficiency, in the way that a party may request a leave or a permission required by the Rules of Procedure and lodge the consequent application by filing only one pleading, especially in a

situation, as the current one, where strict time period come into play.

*Change of the application to amend the patent and relationship between **Rule 50** and **Rule 263 'Rop'**.*

16. The defendant has based its request with the argument that the change of its original application to amend the patent was necessary to counter all the validity attacks to the patent made in the counterclaims filed by Meril Life Sciences Pvt Ltd., parent company of the claimant, and Meril GmbH, European Headquarter, in the proceedings pending before the Munich Local Division of this Court.

17. It has added that in this latter proceedings it filed an application to amend the patent, containing a new main request, as well as 41 auxiliary requests based on 9 individual amendments, and as those counterclaims have been lodged after the expiration of the deadline for submitting the statement of defence to the revocation, it was not possible to establish an aligned line of defence – in particular, an alignment of the amendments and the respective requests in both proceedings – at an earlier stage.

18. It has pointed out that the change of its previous application to amend did not unreasonably hinder the claimant in its conduct of the proceedings, since the proposed amendments were identical to those already submitted in the proceedings pending before the Munich Local Division, which the defendant shall address in that proceedings, and, in any case, were very similar to the amendments originally submitted.

19. It has concluded that as it did not file a new application to amend the patent, but simply sought to amend the previous claim amendments, **Rule 263 (1) 'RoP'** is applicable in this case.

20. Contrary to the defendant's opinion, this panel deems that **Rule 263 (1) 'RoP'** does not apply to the present case for the following reasons.

21. This Rule states that '*A party may at any stage of the proceedings apply to the Court for leave to change its claim or to amend its case, including adding a counterclaim. Any such application shall explain why such change or amendment was not included in the original pleading*' (para 1), adding that leave shall not be granted, unless it limits a claim in an action unconditionally, if, all circumstances considered, the party seeking the amendment cannot satisfy the Court that the amendment in question could not have been made with reasonable diligence at an earlier stage and the amendment will not unreasonably hinder the other party in the conduct of its action (para 2 and 3).

22. The expression '*amend its case*' contained in **Rule 263 'RoP'**, and to which the defendant has referred to, seems to be interpreted in connection of the previous expression '*change its claim*', as they constitute a hendiadys which relates to any modification to the case by the means of the introduction of a new claim or the replacement of the original one ('change its claim'), as the expressed reference to a counterclaim seems to evoke, or of the submission of new or different grounds of the claim ('amend its case').

23. It follows that the request to replace the original application to amend the patent with a new set of amendments appears to be outside the scope of said [Rule 263 'RoP'](#), as it does not pertain to a claim.

24. Actually, the particular case at hand, in which the patent proprietor applied to amend the patent in due time (that is, within the time period for lodging the defence to revocation) and then requested for a change of its original application with the rejoinder to the reply to the defence and the reply to the defence to the application to amend the patent, so that the new amendments superseded the previous ones, falls under [Rule 50 \(2\) 'RoP'](#).

25. This Rule establishes that the application to amend the patent 'shall contain the matters referred to in [Rule 30.1 \(a\), \(c\)](#) and an explanation as to why the amendments satisfy the requirements of [Articles 84 and 123 \(2\), \(3\) EPC](#) and why the proposed amended claims are valid. [Rule 30.2](#) shall apply'.

26. According to this latter [Rule 30 \(2\) 'RoP'](#), any 'subsequent request' to amend the patent may only be admitted into the proceedings with the permission of the Court.

27. The term 'subsequent', present in [Rule 30 \(2\) 'RoP'](#), referred to by [Rule 50 \(2\) 'RoP'](#), has to be interpreted as regarding to an act which follows in succession a previous one and, therefore, it appears clear enough that the term relates to the original application to amend the patent and indicates any request to amend the patent – whether proposed in a completely new version or as an amend of a previous amend – which comes after the first one.

[Rule 30 \(2\) 'RoP'](#) and the use of the discretionary powers by the Court

28. As already mentioned, [Rule 30 \(2\) 'RoP'](#), applicable to the revocation action as referred to by [Rule 50 \(2\) 'RoP'](#), states that 'Any subsequent request to amend the patent may only be admitted into the proceedings with the permission of the Court'.

29. The provision confers to the Court the discretionary powers to admit an amend of the patent even after a previous application of amend of that patent has been submitted and even after the expiration of the time period for amending the patent, that is the time period for lodging of a defence to revocation.

30. While using these discretionary powers the Unified Patent Court judges have to observe the principles of proportionality, flexibility, fairness and equity, mentioned in the [preamble 2 and 4 of](#) the Rules of Procedures (see, [UPC CFI 412/2023 CD Paris, order of 9 February 2024](#)).

31. With particular regard to the admission of a subsequent request to amend the patent, they have to take into account, on one hand, the fact that a subsequent amend of a patent may lead to a more efficient proceedings, narrowing the subject-matter and simplifying the procedural activities, and to a proper safeguard of the interest of the patent proprietor in controlling the scope of protection of its exclusive rights.

32. On the other hand, the admission of subsequent requests to amend the patent may affect the purpose of

delivering an expeditious decision, forcing an extension of the time of the written procedure in relation to the right of the other parties to arrange the consequent defence, and may undermine the right of defence of these latter parties.

33. In order to enable the Court to strike a fair balance between the opposed interests involved in the request to amend the patent the applicant has to offer a justification of its request, explaining why it has decided to change the original request to amend the patent.

The development in Munich LD proceedings as a justification of the subsequent request to amend the patent.

34. The applicant has justified its subsequent request to amend the patent with the fact that in Munich Local Division proceedings, in which it filed an infringement action against Meril Life Sciences Pvt Ltd., parent company of the claimant, and Meril GmbH, European Headquarter, the defendants lodged counterclaims on grounds – after the expiration of the time period for filing an application to amend the patent in the current proceedings – which were not identical to those of the current revocation action, therefore he needed to align the proposed amendments in both proceedings for reasons of consistency and procedural economy.

35. As for the purpose of consistency, the applicant has pointed out that the intention of the Unified Patent Court is to avoid contradicting decisions on the validity of a patent, as shown by the provision [\[Rule 30 \(3\) 'RoP'\]](#) which requires the notification to the Court of any pending applications to amend the disputed patent lodged in other ongoing proceedings.

36. This panel believes that the new amend of the patent is not suitable to fulfil the declared purposes of consistency and procedural economy.

37. As explained in the previous order addressing the preliminary objection lodged by the defendant ([UPC CFI 255/2023 CD Paris, order of 13 November 2023](#)), the Unified Patent Court Agreement ('UPCA') and the Rules of Procedures provide for a set of tools that allow to handle the risk of inconsistent decisions which may derive from the fact that the same patent is attacked by different parties – even if linked by organizational ties or commercial relationships – before different divisions of the Unified Patent Court.

38. In particular, the local or regional division, pursuant to [Article 33 \(3\) 'UPCA'](#), may refer the counterclaim for revocation for decision to the central division and suspend or proceed with the action for infringement or, with the agreement of the parties, refer the case for decision to the central division.

39. Moreover, the tool offered by [Rule 295 \(m\) 'RoP'](#) may come at hand, pushing one of the divisions to stay its proceedings until the decision of the other division and then to decide accordingly on the validity issue.

40. In general, the Unified Patent Court framework does not exclude that a patent may be attacked by different subjects, with different claims, on different grounds and before different divisions and in such a situation the purpose of consistency of the decisions is safeguarded by the mentioned tools and does not require that the

patent proprietor has all its defences in the different proceedings in which its patent is attacked aligned.

41. It may be added that the purpose of consistency of the decisions may come into play only where those decisions address the same subject-matter; therefore it does not seem to be pertaining to the situation at hand where the (subsequent) request to amend the patent has been lodged as a reaction to the attack of its patent brought in a different proceedings on different grounds, that is on grounds that are outside the scope of the current proceedings.

42. The subsequent request to amend the patent may not be justified by the purpose of procedural economy as well.

43. Actually, this principle, which has to be interpreted as to refer to each single proceedings, may be undermined where several applications to amend the patent are lodged, as they would result in an extension of the time of the proceedings and an increase in the number of parties' submissions and, in general, of judicial actions.

44. The defendant does not offer a sufficient explanation on why the efficiency of the revocation action proceedings would benefit from the proposed new set of amendments.

45. Besides, the reference to [Rule 30 \(3\) 'RoP'](#) does not seem to be relevant, as it relates to the duty of the patent proprietor requesting the amend of its patent to notify its application to the Court before which other proceedings involving that patent are pending.

46. Indeed, this provision does not relate to the right of the patent proprietor to amend its patent, but impose a legal obligation aimed at allowing the Court before which the same patent is at issue to adopt the consequent resolutions.

47. For all these arguments, the claimant's application is founded and the leave requested by the defendant (recte, the permission to amend the patent) shall not be granted, without any need of hearing the parties pursuant to [Rule 264 'RoP'](#), as requested by the defendant, as a written consultation of the parties have taken place and this panel does not deem necessary to carry out further consultation on the application at hand, neither in a written way nor in an oral way.

Further considerations.

48. The rejection of the defendant's request leads to the conclusion that, at this moment, the current proceedings will address the invalidity grounds alleged by the claimant with regard to the defendant's patent without taking into account the amendments proposed with the rejoinder to the reply to the statement of defence and reply to the defence to the application to amend the patent lodged on 22 January 2024.

49. This does not preclude the parties from agreeing, during the proceedings, on a new set of amendments that may incorporate some of those previously rejected by this order, if such amendments align with their best interests.

Request to hear the revocation action together with the counterclaims in the Munich Local Division proceedings.

50. In its comments on the application at hand the defendant has requested that revocation action be heard together with the counterclaims for revocation brought by Meril Life Sciences Pvt Ltd. and Meril GmbH before the Munich Local Division against the patent in suit, pursuant to [Rule 340 \(1\) 'RoP'](#) and, should the Court not follow that request, the Court hears the parties pursuant to the same Rule.

51. The opinion of this panel is that this request may have not been made at this stage of the proceedings: firstly, because the lodging of the defendant's pleading has been authorised by the judge-rapporteur with regard to the only purpose of commenting the claimant's application.

52. Secondly, regardless to any considerations about the scope of [Rule 340 'RoP'](#), the application of that Rule does not appear to be actual, as no hearing seems to have been set in the two proceedings.

Request to grant leave to appeal.

53. The panel decides not to grant leave to appeal, because, in the absence of any precedents from the Unified Patent Court on the disputed issue, there is no concrete need for a ruling on the meaning of the relevant rules.

54. Furthermore, the panel reminds the parties that, as previously mentioned, a different set of amendments may be reached, upon their agreement, during the course of the proceedings.

55. Lastly, the panel notes that in case of a possible immediate appeal to this order a decision by the Court of appeal may intervene after that the oral hearing in the current proceedings has taken place and, therefore, would be of no practical use to the parties.

ORDER

For these grounds the panel:

- grants the claimant's request and, therefore, rejects the defendant's application for leave to amend the case lodged on 22 January 2024;
- rejects the defendant's auxiliary request that the Court hears the parties pursuant to [Rule 264 'RoP'](#);
- rejects the defendant's request that the revocation action to be heard together with the counterclaim for revocation pending before the Munich Local Division (CFI_15/2023) and the auxiliary request that the Court hears the parties pursuant to [Rule 340 \(1\) 'RoP'](#);
- reject the defendant's request that the Court grants leave to appeal.

Issued on 27 February 2024

The Presiding judge and judge-rapporteur Paolo Catalozzi

The legally qualified judge Tatyana Zhilova

The technical qualified judge Stefan Wilhelm
